

3050K

N-Channel Trench Power MOSFET

N-Channel Trench Power MOSFET

General Description

The 3050K uses advanced trench technology to provide excellent $R_{DS(ON)}$, low gate charge and operation with gate voltages as low as 4.5V. This device is suitable for use as a wide variety of applications.

Features

- $V_{DS} = 30V, I_D = 50A$
 $R_{DS(ON)} < 9m\Omega @ V_{GS} = 10V$
 $R_{DS(ON)} < 17m\Omega @ V_{GS} = 4.5V$
- High Power and current handing capability
- Lead free product is acquired
- Surface Mount Package

Application

- PWM applications
- Load switch
- Power management

100% UIS TESTED!
100% ΔV_{ds} TESTED!

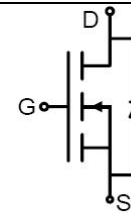

Schematic Diagram

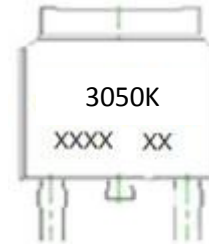

Marking and pin Assignment

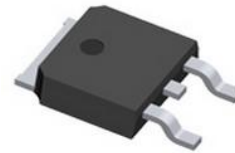

TO-252(DPAK) top view

Package Marking and Ordering Information

Device Marking	Device	Device Package	Reel Size	Tape width	Quantity
3050K	3050K	TO-252	325mm	16mm	2500

Table 1. Absolute Maximum Ratings ($T_A=25^\circ C$)

Symbol	Parameter	Value	Unit
V_{DS}	Drain-Source Voltage ($V_{GS}=0V$)	30	V
V_{GS}	Gate-Source Voltage ($V_{DS}=0V$)	± 20	V
I_D	Drain Current-Continuous($T_c=25^\circ C$) (Note 1)	50	A
	Drain Current-Continuous($T_c=100^\circ C$)	35	A
$I_{DM (pluse)}$	Drain Current-Continuous@ Current-Pulsed (Note 2)	200	A
P_D	Maximum Power Dissipation($T_c=25^\circ C$)	50	W
	Maximum Power Dissipation($T_c=100^\circ C$)	25	W
E_{AS}	Avalanche energy (Note 3)	90	mJ
T_J, T_{STG}	Operating Junction and Storage Temperature Range	-55 To 175	$^\circ C$

Table 2. Thermal Characteristic

Symbol	Parameter	Typ	Max	Unit
$R_{\theta JC}$	Thermal Resistance, Junction-to-Case	-	3	$^\circ C/W$

3050K

N-Channel Trench Power MOSFET

Table 3. Electrical Characteristics (TA=25°C unless otherwise noted)

Symbol	Parameter	Conditions	Min	Typ	Max	Unit
On/Off States						
BV _{DSS}	Drain-Source Breakdown Voltage	V _{GS} =0V I _D =250μA	30			V
I _{DSS}	Zero Gate Voltage Drain Current	V _{DS} =30V, V _{GS} =0V			1	μA
I _{GSS}	Gate-Body Leakage Current	V _{GS} =±20V, V _{DS} =0V			±100	nA
V _{GS(th)}	Gate Threshold Voltage	V _{DS} =V _{GS} , I _D =250μA	1.0	1.5	2.5	V
g _{FS}	Forward Transconductance	V _{DS} =5V, I _D =20A	10	20		S
R _{DS(on)}	Drain-Source On-State Resistance	V _{GS} =10V, I _D =20A		7.2	9.0	mΩ
		V _{GS} =4.5V, I _D =15A		11	17	mΩ
Dynamic Characteristics						
C _{iss}	Input Capacitance	V _{DS} =15V, V _{GS} =0V, f=1.0MHz		1050		pF
C _{oss}	Output Capacitance			145		pF
C _{rss}	Reverse Transfer Capacitance			120		pF
R _g	Gate resistance	V _{GS} =0V, V _{DS} =0V, f=1.0MHz		2		Ω
Switching Times						
t _{d(on)}	Turn-on Delay Time	V _{GS} =10V, V _{DS} =15V, R _L =0.75Ω, R _{GEN} =3Ω		7		nS
t _r	Turn-on Rise Time			22		nS
t _{d(off)}	Turn-Off Delay Time			30		nS
t _f	Turn-Off Fall Time			5		nS
Q _g	Total Gate Charge	V _{GS} =10V, V _{DS} =25V, I _D =12A		22		nC
Q _{gs}	Gate-Source Charge			4		nC
Q _{gd}	Gate-Drain Charge			7		nC
Source-Drain Diode Characteristics						
I _{SD}	Source-Drain Current(Body Diode)				50	A
V _{SD}	Forward on Voltage	V _{GS} =0V, I _S =20A			1.2	V

Notes 1.The maximum current rating is package limited.

Notes 2.Repetitive Rating: Pulse width limited by maximum junction temperature

Notes 3.EAS condition: T_J=25°C, V_{DD}=30V, V_G=10V, R_G=25Ω

Test Circuit

1) E_{AS} Test Circuits

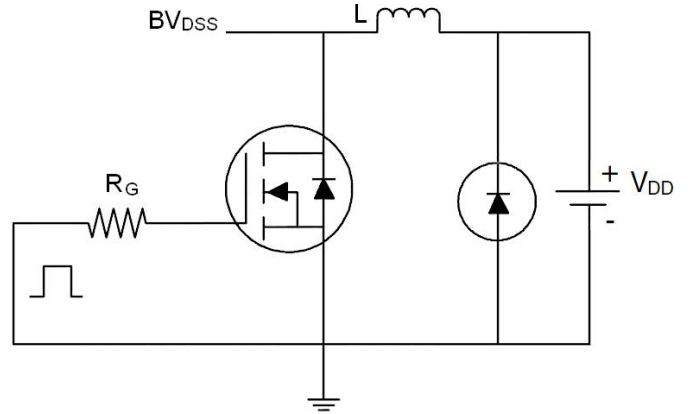
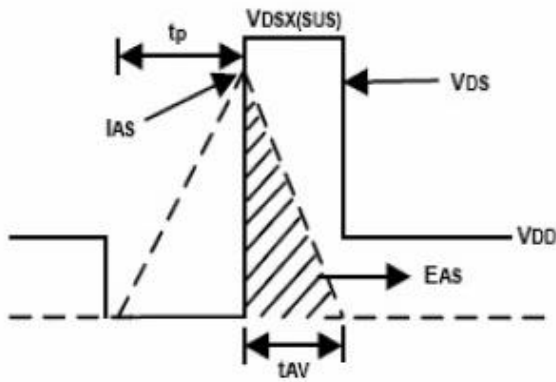

2) Gate Charge Test Circuit:

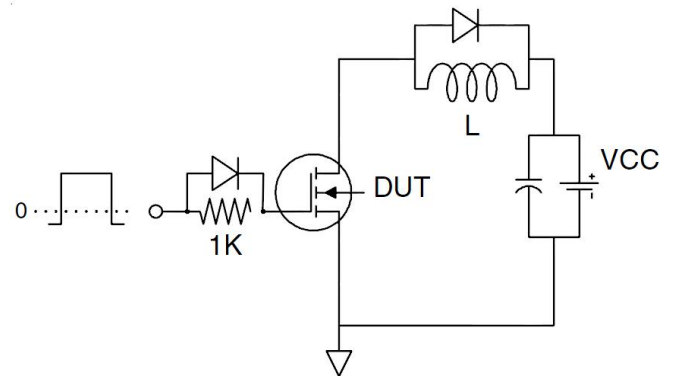
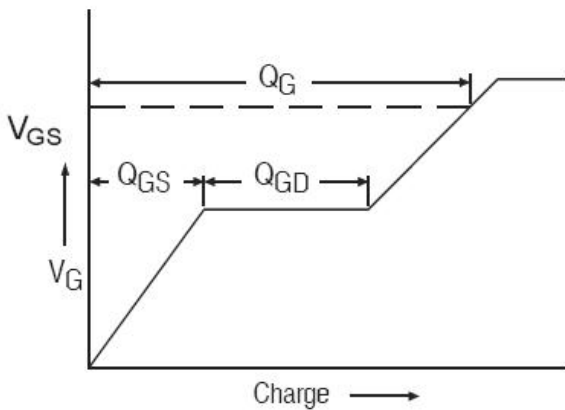

3) Switch Time Test Circuit:

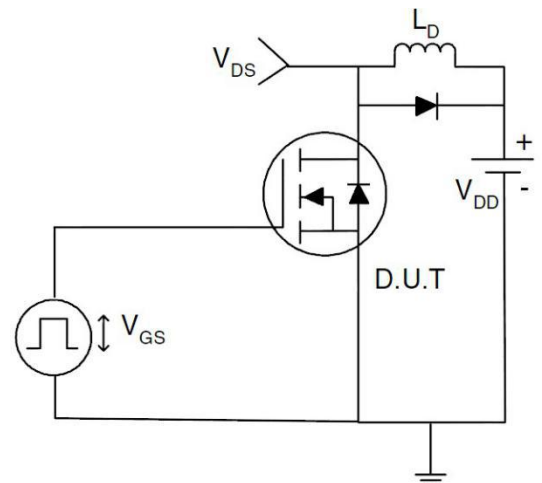
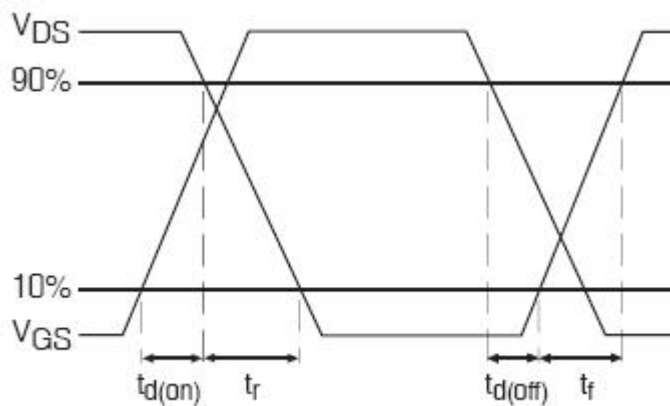

TYPICAL ELECTRICAL AND THERMAL CHARACTERISTICS(Curves)

Figure 1. Output Characteristics

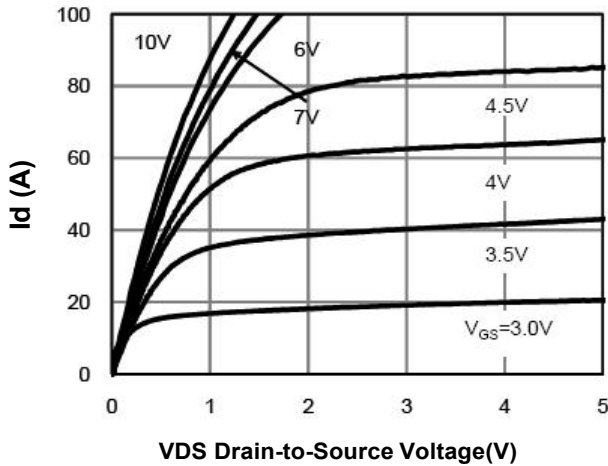

Figure 2. Transfer Characteristics

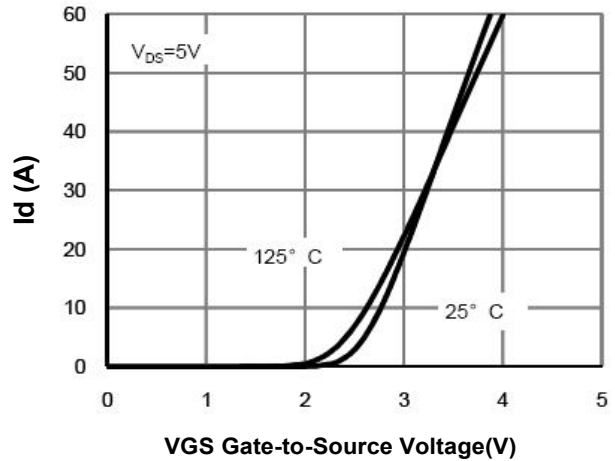

Figure 3. Max BV_{DSS} vs Junction Temperature

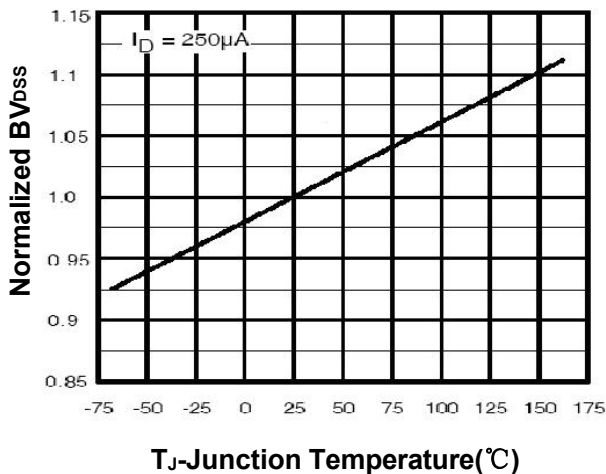

Figure 4. Drain Current

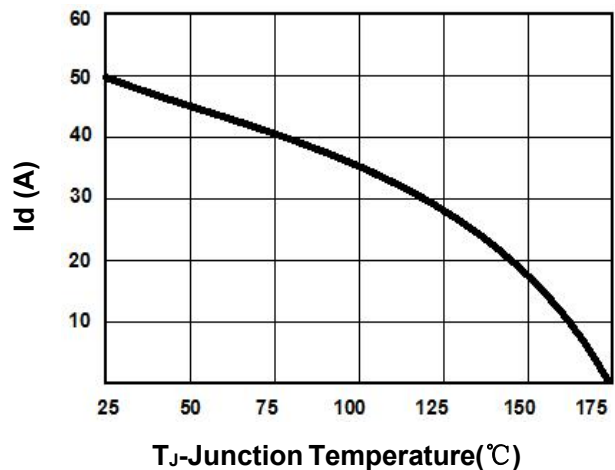

Figure 5. $V_{GS(th)}$ vs Junction Temperature

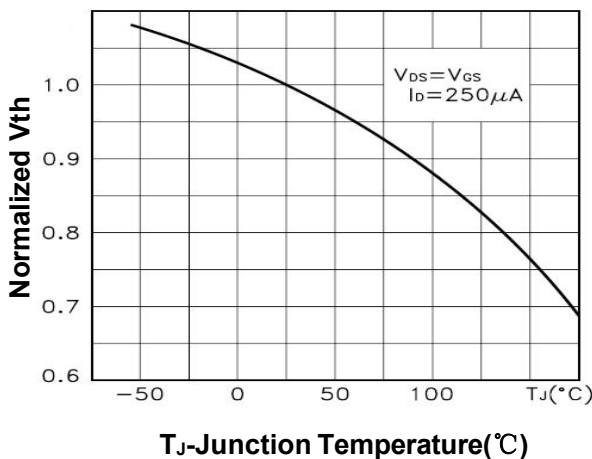

Figure 6. $R_{DS(on)}$ vs Junction Temperature

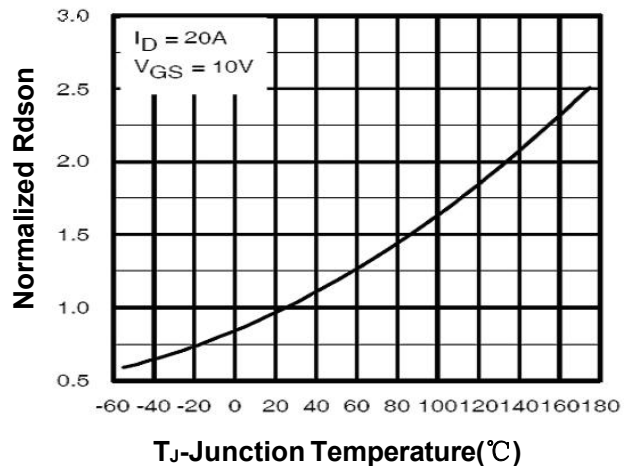

Figure 7. Gate Charge Waveforms

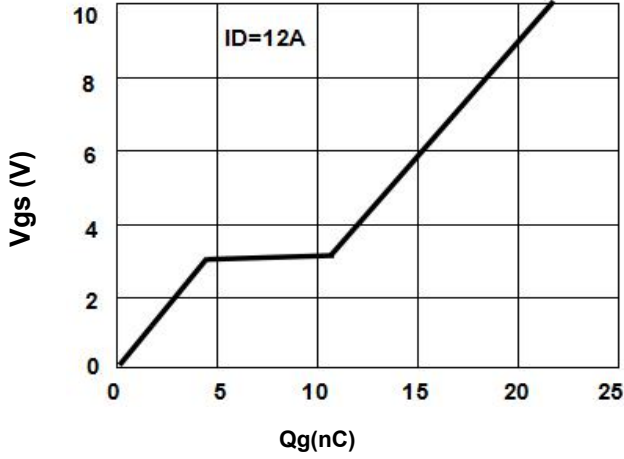

Figure 8. Capacitance

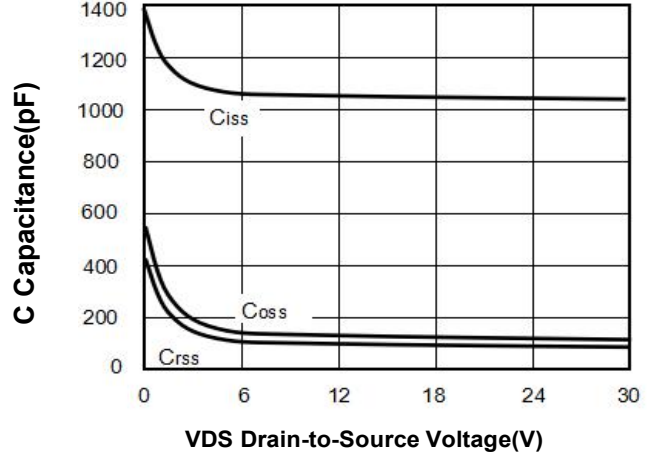

Figure 9. Body-Diode Characteristics

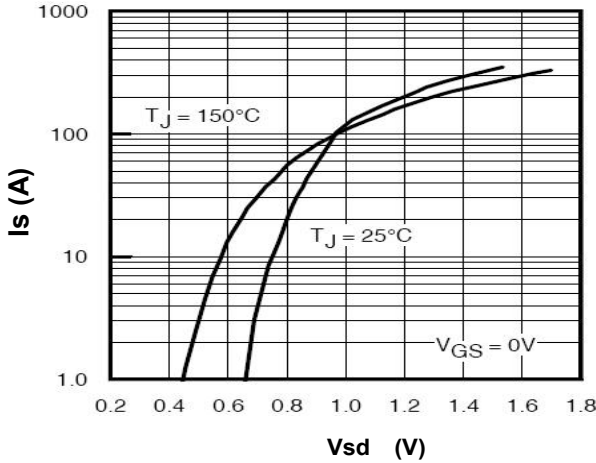

Figure 10. Maximum Safe Operating Area

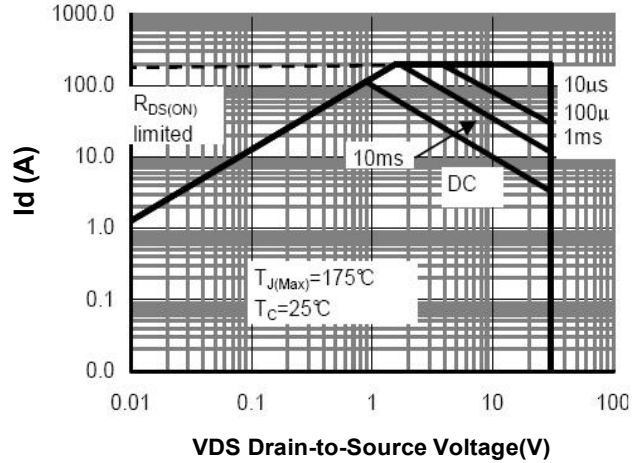
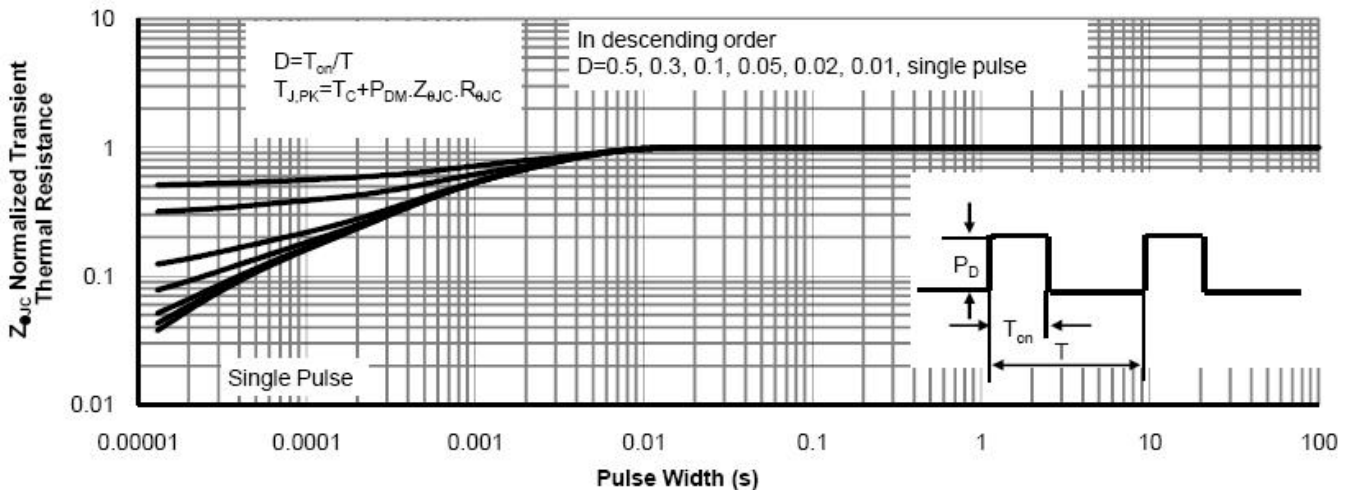
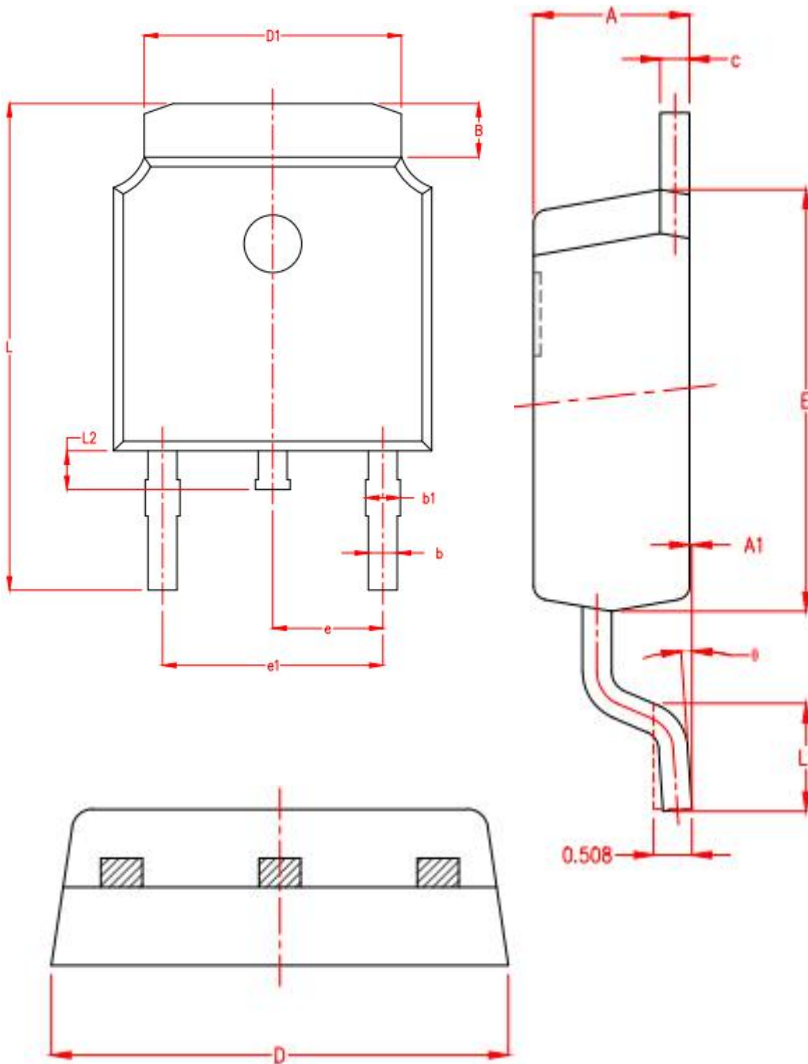

Figure 11. Normalized Maximum Transient Thermal Impedance



TO-252 Package Information



SYMBOL	MILLIMETER		
	MIN	NOM	MAX
A	2.15	2.25	2.35
A1	0.00	0.06	0.12
B	0.96	1.11	1.26
b	0.59	0.69	0.79
b1	0.69	0.81	0.93
c	0.34	0.42	0.50
D	6.45	6.60	6.75
D1	5.23	5.33	5.43
E	5.95	6.10	6.25
e	2.286TYP.		
e1	4.47	4.57	4.67
L	9.90	10.10	10.30
L1	1.40	1.55	1.70
L2	0.60	0.80	1.00
θ	0°	4°	8°