

1.0MHz, 2A Synchronous Step-Down Converter

FEATURES

- High Efficiency: Up to 96%
- 1.0MHz Constant Frequency Operation
- 2A Output Current
- No Schottky Diode Required
- 2.3V to 6V Input Voltage Range
- Output Voltage as Low as 0.6V
- PFM Mode for High Efficiency in Light Load
- 100% Duty Cycle in Dropout Operation
- Low Quiescent Current: 40 μ A
- Short Circuit Protection
- Thermal Fault Protection
- Inrush Current Limit and Soft Start
- Input overvoltage protection(OVP)
- <1 μ A Shutdown Current
- SOT23-5 package

APPLICATIONS

- Cellular and Smart Phones
- Wireless and DSL Modems
- PDAs
- Portable Instruments
- Digital Still and Video Cameras
- PC Cards

GENERAL DESCRIPTION

The TC3488A are high-efficiency, high frequency synchronous step-down DC-DC regulator ICs capable of delivering up to 2.0A output currents. The

TC3488A can operate over a wide input voltage range from 2.3V to 6.0V and integrate main switch and synchronous switch with very low RDS(ON) to minimize the conduction loss.

It is ideal for powering portable equipment that runs from a single cell Lithium-Ion (Li+) battery. The output voltage can be regulated as low as 0.6V. The

TC3488A can also run at 100% duty cycle for low dropout operation, extending battery life in portable system. This device offers two operation modes, PWM control and PFM Mode switching control, which allows a high efficiency over the wider range of the load.

The TC3488A is offered in a low profile (1mm) 5-pin, thin SOT package, and is available in an adjustable version.

TYPICAL APPLICATION

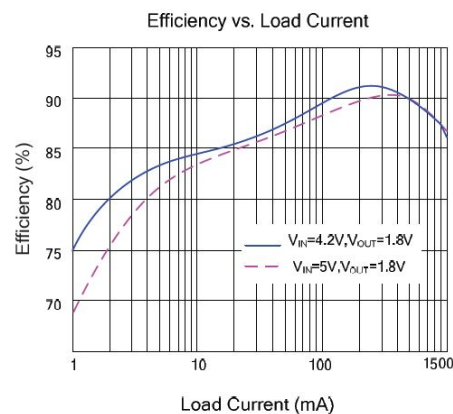
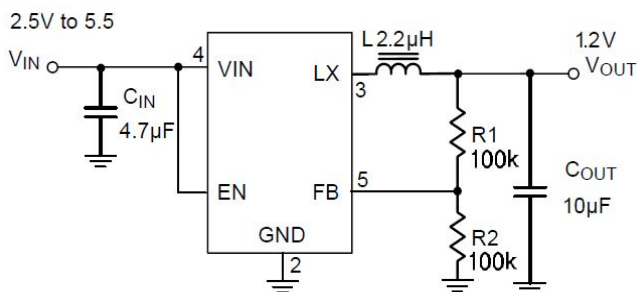

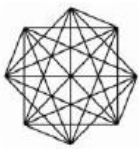

ABSOLUTE MAXIMUM RATINGS (Note 1)

Input Supply Voltage	-0.3V to 6.0V	Operating Temperature Range ...	-40°C to +85°C
RUN, VOUT Voltages	-0.3V to 6.0V	Junction Temperature(Note2)	125°C
SW Voltage	-0.3V to (Vin+0.3V)	Storage Temperature Range	-65°C to 150°C
Peak SW Sink and Source Current	2.5 A	Lead Temperature(Soldering, 10s)	+300°C

PACKAGE/ORDER INFORMATION

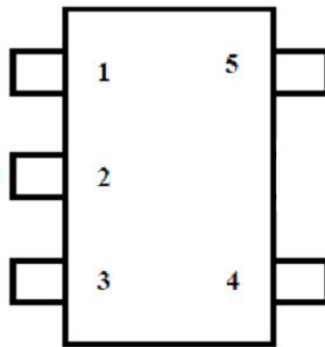

(SOT23-5)

Top Mark: **S15XXX** (S15: Device Code, XXX: Week Code)

Part Number	SWICHING FREQUENCY	Temp Range	OUTPUT VOLTAGE (V)	OUTPUT CURRENT (A)
TC3488A	1.0MHz	-40°C to +85°C	ADJ	2.0

PIN DESCRIPTION

PIN	NAME	FUNCTION
1	RUN	Chip Enable Pin. Drive RUN above 1.5V to turn on the part. Drive RUN below 0.3V to turn it off. Do not leave RUN floating.
2	GND	Ground Pin
3	SW	Power Switch Output. It is the switch node connection to Inductor. This pin connects to the drains of the internal P-ch and N-ch MOSFET switches.
4	VIN	Power Supply Input. Must be closely decoupled to GND with a 10μF or greater ceramic capacitor.
5	VOUT	Output Voltage Feedback Pin. An internal resistive divider divides the output voltage down for comparison to the internal reference voltage.

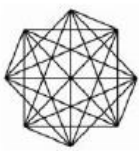

ELECTRICAL CHARACTERISTICS

($V_{IN}=V_{RUN}=3.6V$, $V_{OUT}=1.8V$, $T_A = 25^{\circ}C$, unless otherwise noted.)

Parameter	Conditions	MIN	TYP	MAX	unit
Input Voltage Range		2.3		6.0	V
OVP Threshold			6.5		V
UVLO Threshold		1.7	1.9	2.1	V
Input DC Supply Current	(Note 4)				μA
PWM Mode	$V_{out} = 90\%$, $I_{load}=0mA$		140	300	μA
PFM Mode	$V_{out} = 105\%$, $I_{load}=0mA$		35	70	μA
Shutdown Mode	$V_{RUN} = 0V$, $V_{IN}=4.2V$		0.1	1.0	μA
Regulated Feedback Voltage	$T_A = 25^{\circ}C$	0.588	0.600	0.612	V
	$T_A = 0^{\circ}C \leq T_A \leq 85^{\circ}C$	0.586	0.600	0.613	V
	$T_A = -40^{\circ}C \leq T_A \leq 85^{\circ}C$	0.585	0.600	0.615	V
Reference Voltage Line Regulation	$V_{in}=2.3V$ to $6.0V$		0.04	0.40	%/V
Output Voltage Line Regulation	$V_{IN} = 2.3V$ to $6.0V$		0.04	0.4	%
Output Voltage Load Regulation			0.5		%
Oscillation Frequency	$V_{out}=100\%$		1.0		MHz
	$V_{out}=0V$		300		KHz
On Resistance of PMOS	$I_{SW}=100mA$		0.2		Ω
ON Resistance of NMOS	$I_{SW}=-100mA$		0.13		Ω
Peak Current Limit	$V_{IN}= 3V$, $V_{out}=90\%$ 3410A		2.5		A
	$V_{IN}= 3V$, $V_{out}=90\%$ 3410		2.5		A
RUN Threshold		0.30	1.0	1.50	V
RUN Leakage Current			± 0.01	± 1.0	μA
SW Leakage Current	$V_{RUN}=0V$, $V_{IN}=V_{sw}=5V$		± 0.01	± 1.0	μA

Note 1: Absolute Maximum Ratings are those values beyond which the life of a device may be impaired.

Note 2: T_J is calculated from the ambient temperature T_A and power dissipation P_D according to the following formula:

$$T_J = T_A + (P_D) \times (250^{\circ}C/W).$$

Note3: 100% production test at $+25^{\circ}C$. Specifications over the temperature range are guaranteed by design and characterization.

Note 4: Dynamic supply current is higher due to the gate charge being delivered at the switching frequency

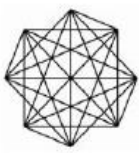

FUNCTIONAL BLOCK DIAGRAM

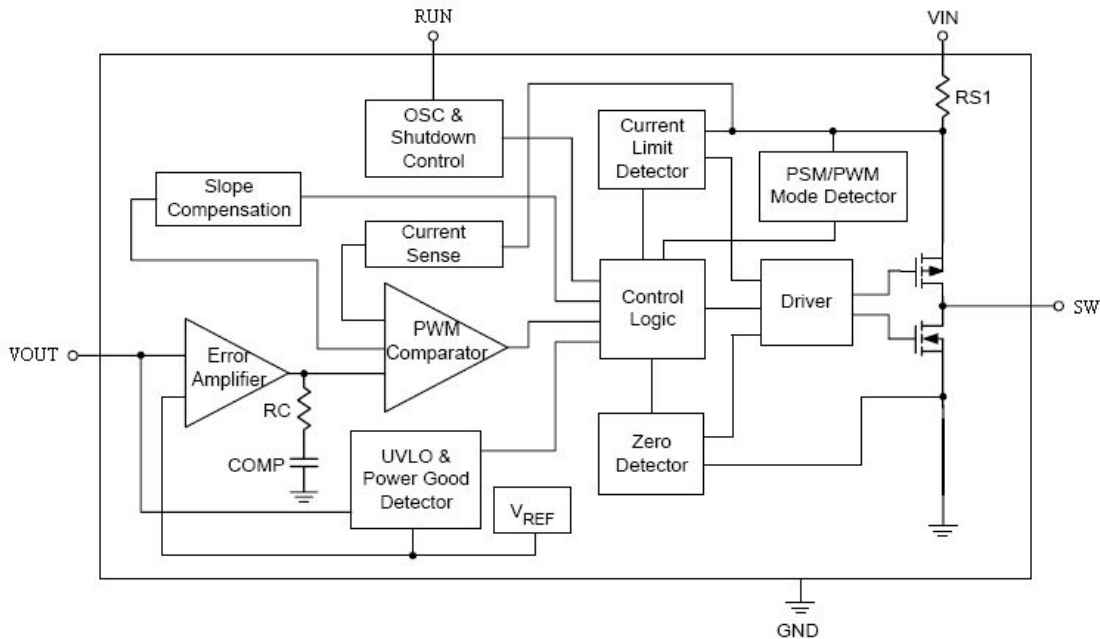

Figure 3. TC3488A Block Diagram

FUNCTIONAL DESCRIPTION

TC3488A is a synchronous buck regulator IC that integrates the PWM/PFM control, top and bottom switches on the same die to minimize the switching transition loss and conduction loss. With ultra low RDS(ON) power switches and proprietary PWM control, this regulator IC can achieve the highest efficiency and the highest switch frequency simultaneously to minimize the external inductor and capacitor size, and thus achieving the minimum solution footprint.

The TC3488A requires only three external power components (Cin, Cout and L). The adjustable version can be programmed with external feedback to any voltage, ranging from 0.6V to the input voltage. At dropout, the converter duty cycle increases to 100% and the output voltage tracks the input voltage minus the Rdson drop of the high-side MOSFET.

The internal error amplifier and compensation provides excellent transient response, load, and line regulation. Soft start function prevents input inrush current and output overshoot during start up.



APPLICATIONS INFORMATION

Setting the Output Voltage

The external resistor divider is used to set the output voltage (see Typical Application on page 1). The feedback resistor R1 also sets the feedback loop bandwidth with the internal compensation capacitor. Choose R1 to be around 100kΩ for optimal transient response. R2 is then given by:

$$R_2 = \frac{R_1}{V_{out} / V_{FB} - 1}$$

Inductor Selection

For most designs, the TC3488A operates with inductors of 1μH to 4.7μH. Low inductance values are physically smaller but require faster switching, which results in some efficiency loss. The inductor value can be derived from the following equation:

$$L = \frac{V_{OUT} \times (V_{IN} - V_{OUT})}{V_{IN} \times \Delta I_L \times f_{OSC}}$$

Where ΔI_L is inductor Ripple Current. Large value inductors result in lower ripple current and small value inductors result in high ripple current. For optimum voltage-positioning load transients, choose an inductor with DC series resistance in the 50mΩ to 150mΩ range.

Input Capacitor Selection

With the maximum load current at 2.0A, the maximum ripple current through input capacitor is about 0.6Arms. A typical X7R or better grade ceramic capacitor with 6V rating and greater than 10uF capacitance can handle this ripple current well. To minimize the potential noise problem, place this ceramic capacitor really close to the IN and GND pins. Care should be taken to minimize the loop area formed by CIN, and IN/GND pins.

Output Capacitor Selection

The output capacitor is required to keep the output voltage ripple small and to ensure regulation loop stability. The output capacitor must have low impedance at the switching frequency. Ceramic capacitors with X5R or X7R dielectrics are recommended due to their low ESR and high ripple current ratings. The output ripple V_{OUT} is determined by:

$$\Delta V_{OUT} \leq \frac{V_{OUT} \times (V_{IN} - V_{OUT})}{V_{IN} \times f_{OSC} \times L} \times \left(ESR + \frac{1}{8 \times f_{osc} \times C3} \right)$$

A 10μF ceramic can satisfy most applications.



PC Board Layout Checklist

When laying out the printed circuit board, the following checking should be used to ensure proper operation of the TC3488A. Check the following in your layout:

1. The power traces, consisting of the GND trace, the SW trace and the VIN trace should be kept short, direct and wide.
2. Does the (+) plates of C_{in} connect to V_{in} as closely as possible? This capacitor provides the AC current to the internal power MOSFETs.
3. Keep the switching node, SW, away from the sensitive VOUT node.
4. Keep the (-) plates of C_{in} and C_{out} as close as possible

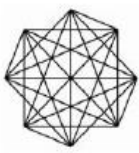

PACKAGE DESCRIPTION

SOT23-5

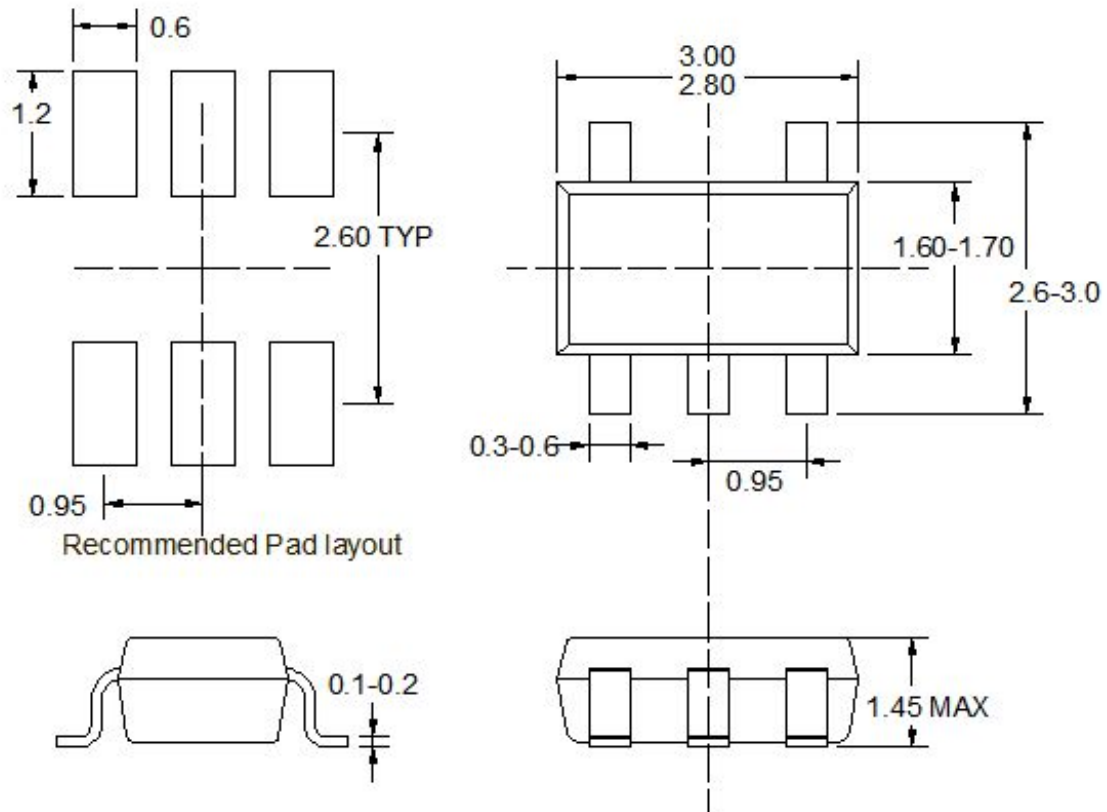

Note:

- 1) All dimensions are in millimeters.
- 2) Package length does not include mold flash, protrusion or gate burr.
- 3) Package width does not include interlead flash or protrusion.
- 4) Lead coplanarity (bottom of leads after forming) shall be 0.10 millimeters max.
- 5) Pin 1 is lower left pin when reading top mark from left to right,